



Emax

HIGH ENERGY BALL MILL

THE REVOLUTION IN ULTRAFINE GRINDING



RETSCH – Global market leader in the preparation and characterization of solids

www.retsch.com



RETSCH – More than 100 Years of Innovation

Premium Quality „Made in Germany“

RETSCH is the leading solution provider for size reduction and particle sizing technology with subsidiaries in the US, China, Japan, India, France, Italy, Benelux, Russia, UK and Thailand. The company was founded in 1915 by F. Kurt Retsch and earned an excellent reputation in the international science and research community with the „Retsch Mill“ - a mortar grinder that replaced grinding with hand mortars.

RETSCH's philosophy is based on customer orientation and leading edge technology. This is reflected in instruments whose high-quality components are designed for perfect interaction. Our products not only guarantee representative and reproducible results for size reduction and particle analysis but also allow for easy and comfortable operation.

With RETSCH you get:

- ▶ First class product quality thanks to advanced manufacturing methods
- ▶ Comprehensive application support including free test grindings and product trainings
- ▶ Excellent sales and service network throughout the world

PREMIUM QUALITY



MADE IN GERMANY

High Energy Milling

Controlled forces provide optimum results in a short time

New technologies pose new challenges to science and research which is also reflected in the performance features of the laboratory equipment involved. Nanotechnology, a typical example as one of the most innovative developments of our times, deals with particles in a size range from 1 to 100 nanometers that have special properties attributable to their size. Another example is materials science which uses processes like mechanical alloying to develop new materials. Both size reduction on a nanometer scale and mechanical alloying require very high energy input.

As this usually means heat build-up, effective temperature control is an essential requirement.

RETSCH is the leading manufacturer of laboratory mills for homogenization of solid samples and has developed a High Energy Ball Mill which fulfills all these requirements. With a unique maximum speed of 2000 rpm and innovative cooling options, the Emax is ideally suited for high energy applications.

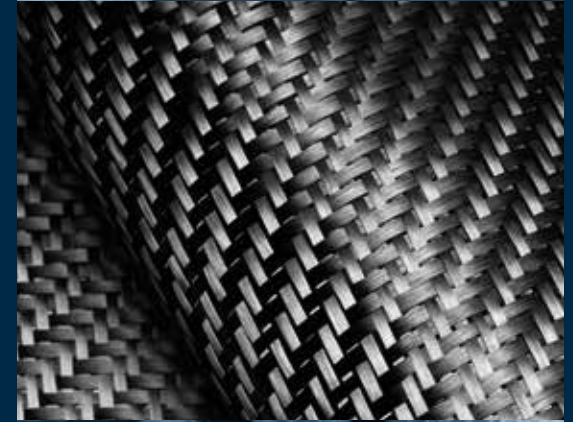



Emax – The Revolution in Ultrafine Grinding

The Emax is an entirely new ball mill designed for high energy grinding. The maximum speed of 2000 rpm, so far unrivaled in a ball mill, and the innovative jar design produce highly effective size reduction by impact and friction. The grinding jar geometry in combination with the circular movements of the jars results in better mixing of the sample, higher final fineness and narrower particle size distributions than has been achieved so far in other ball mills. Thanks to the unique size reduction mechanism, the Emax delivers the desired grind sizes after very short processing times.

In contrast to conventional ball mills, grinding processes up to several hours can be carried out in the Emax without cooling breaks. The innovative water cooling system ensures that the high energy input is effectively used for the grinding process and that the sample is not overheated. The temperature control mode allows the user to define a maximum temperature which will not be exceeded during the process.

All these features make the Emax ideally suited for high energy grinding in a fraction of the time required by conventional ball mills – and mostly with better results.



High Energy Ball Mill Emax

- ▶ Faster grinding than with any other ball mill
- ▶ Revolutionary speed of 2000 rpm
- ▶ Unique size reduction principle
- ▶ Innovative water cooling with 3 cooling modes
- ▶ Temperature control
- ▶ Grind sizes in the nanometer range

PREMIUM QUALITY



MADE IN GERMANY

Superiority in Detail



ADVANTAGE EMAX:
Unique grinding jar geometry provides thorough mixing of the sample and narrow particle size distribution

ADVANTAGE EMAX:
Ergonomic clamping device ensures safe and easy mounting of grinding jars

ADVANTAGE EMAX:
Patented eccentric drive permits maximum speed of 2000 rpm

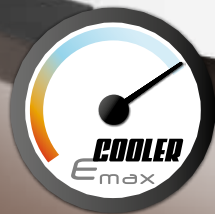

ADVANTAGE EMAX:
Innovative water cooling with 3 cooling modes allows for grinding without breaks and prevents the sample from overheating

ADVANTAGE EMAX:
Large touchscreen with display of temperature, speed and process time

ADVANTAGE EMAX:
Temperature control allows definition of a maximum temperature at which the mill interrupts the grinding process, as well as a minimum temperature at which the mill resumes grinding



Intuitive operation

1. Inserting the grinding jar
2. Closing the jar clamp
3. Operating the touchscreen



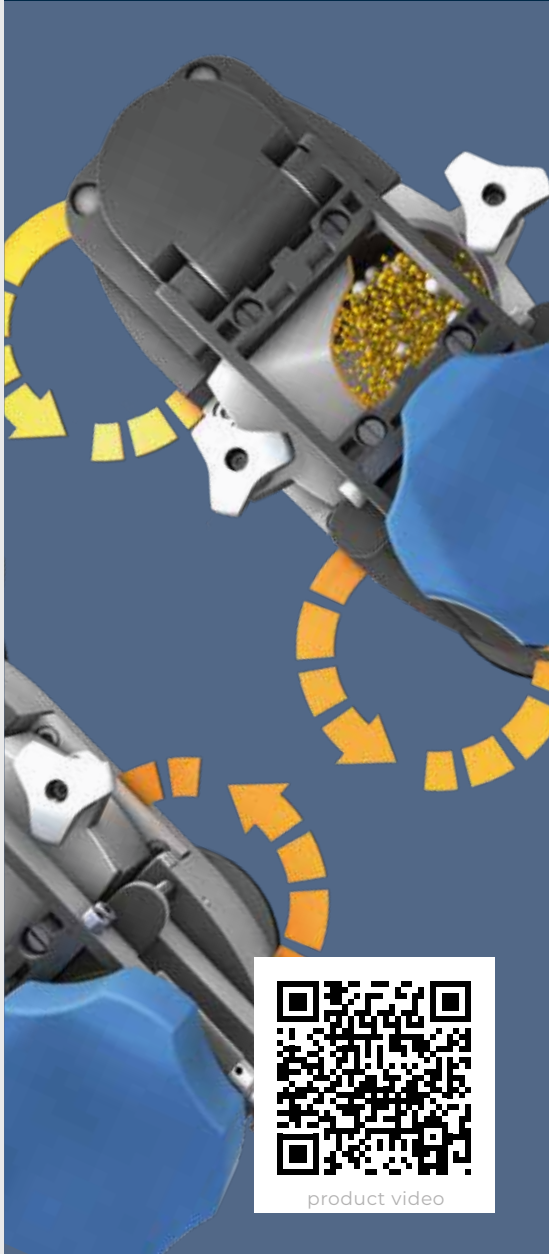

Functional Principle

Unique size reduction mechanism produces grind sizes in the submicron range

The High Energy Ball Mill Emax combines high-frequency impact, intensive friction, and controlled circular jar movements to a unique and highly effective size reduction mechanism.

The grinding jars have an oval shape and are mounted on two discs respectively which move the jars on a circular course without changing their orientation. The interplay of jar geometry and movement causes strong friction between the grinding balls, sample material and jar walls as well as a rapid acceleration which lets the balls impact with great force on the sample at the rounded ends

of the jars. This significantly improves the mixing of the particles resulting in smaller grind sizes and a narrower particle size distribution than is possible to achieve in ball mills.

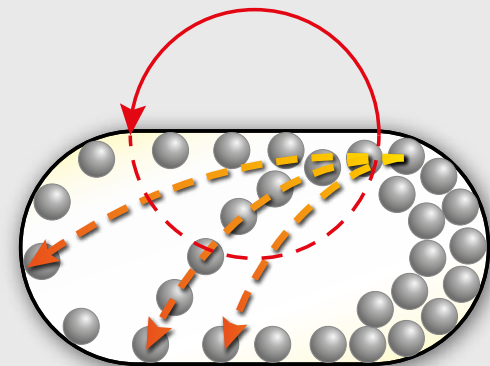

Operation & Safety

Safe handling of extreme forces

Special focus was placed on operating convenience and safety when developing the Emax. The grinding jar lids with integrated safety closure, which are simply screwed onto the jars, ensure absolute tightness for wet grinding processes or in cases of pressure increase inside the jar. The grinding jars are quickly and easily placed in the mill and are safely clamped with the ergonomic hand wheel. A sensor monitors the correct position of the jars before starting the machine. Possible imbalances are permanently monitored; if they become too strong the

mill stops automatically and the remaining grinding time is displayed.

Grinding parameters such as speed, time, interval operation or temperature control are quickly and conveniently set via the color touchscreen. The temperature is displayed during the entire grinding process. The user can store up to 10 grinding programs for routine operations.



Color touchscreen

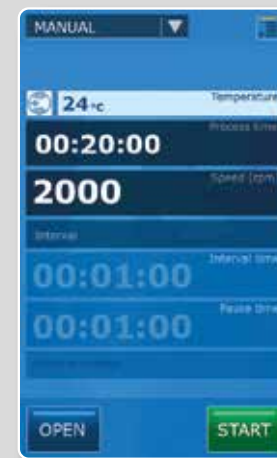

Start screen with temperature display



Speed setting



Setting of minimum and maximum temperature

Highly Efficient Cooling System

makes cooling breaks obsolete

The greatest challenge when developing a high energy ball mill is keeping the temperature under control as the enormous size reduction energy leads to considerable heat built-up inside the grinding jar. RETSCH solved this problem with an innovative integrated water cooling system. Hence, the Emax usually doesn't require cooling

breaks which are typical for long-term processes in conventional ball mills, even at low speed.

In the Emax the cooling system cools the grinding jars via the jar brackets. This is very effective because heat is more easily discharged into water than into air.

The user can choose between 3 cooling modes: in addition to the internal cooling, the mill can be connected to a chiller or the tap to further reduce the temperature.

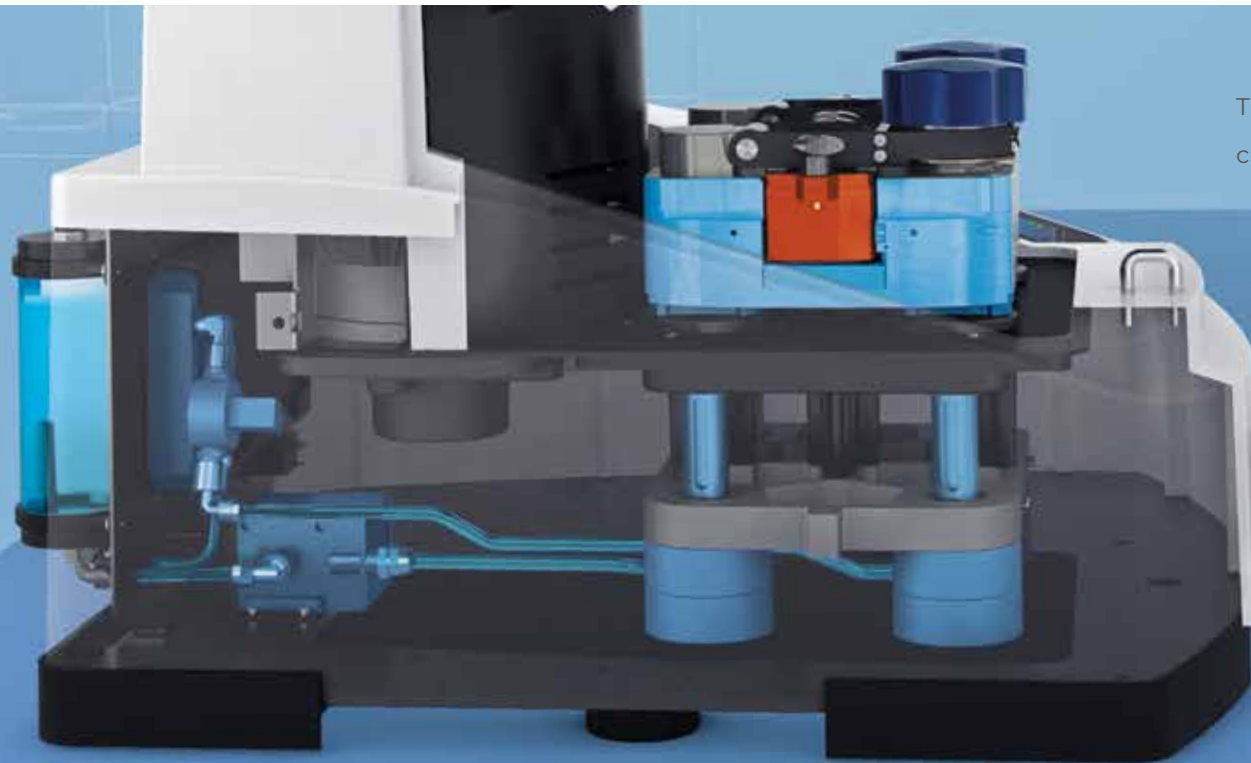

The graphic shows the cooling circle inside the Emax

3 cooling modes offer flexibility

1. Internal water cooling
2. Additional external cooling possible by connecting the mill to the tap
3. Maximum water cooling by using an optional chiller



Example temperature development*

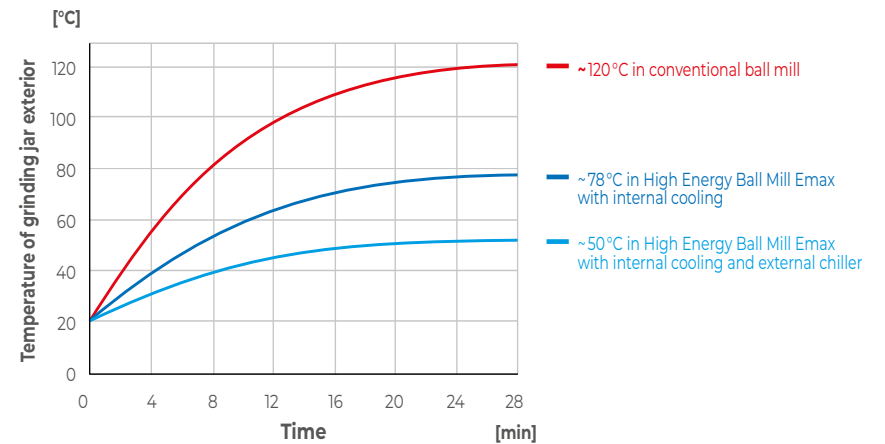

* Temperatures depend on sample material, instrument configuration, and ambient temperature and may differ from this example

Temperature Control Mode

for heat-sensitive samples

The Emax software allows the user to carry out the grinding process within a defined temperature range, i.e. it is possible to define a minimum and a maximum temperature. On reaching the maximum temperature, the mill automatically interrupts the grinding process and resumes it when the jar has cooled down to the minimum temperature.

The possibility to define a maximum temperature is essential for grinding heat-sensitive sample materials. When using conventional ball mills the adequate cycles of grinding and cooling need to be ascertained by empirical trials. This may lead to degeneration of the sample or to unnecessarily long processing times. The Emax, in contrast, allows for variable cycles of

grinding and cooling within the defined temperature limits. Thus the entire size reduction process remains reproducible and is carried out in the shortest possible time.

Applications

Pulverizing, Homogenizing, Alloying

The High Energy Ball Mill Emax is used wherever highest demands are placed on speed, fineness, purity and reproducibility. The Emax pulverizes and homogenizes medium-hard, hard, brittle and fibrous materials – dry or wet – and easily produces grind sizes down to the nanometer range.

Its efficiency and flexibility makes the Emax suitable for a wide range of materials – from pulverizing ingredients for pharmaceutical research to mechanical alloying for the development of new materials.

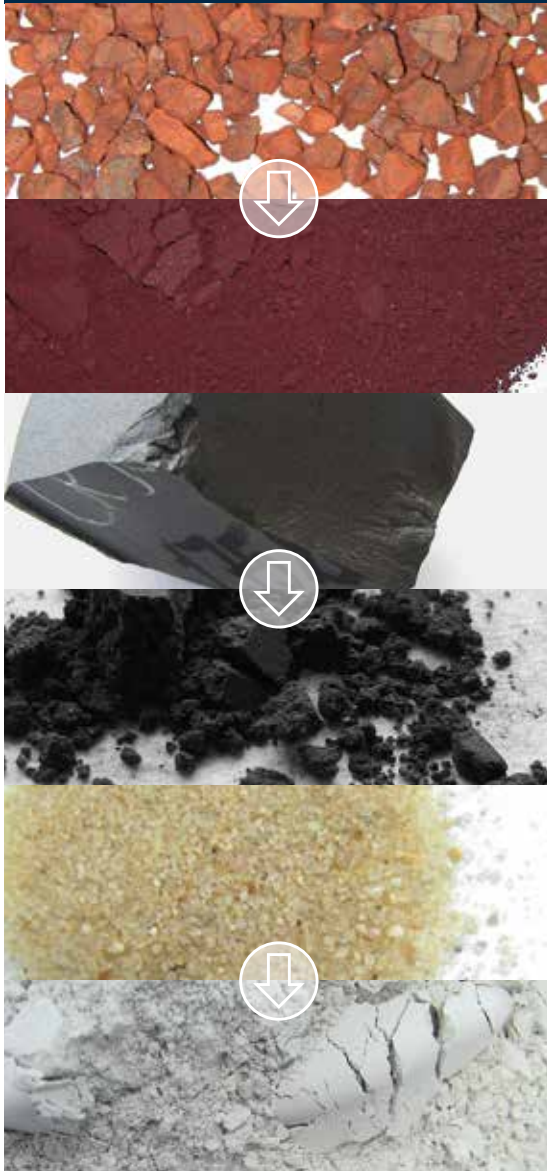

Typical Sample Materials

RETSCH's High Energy Ball Mill Emax is ideal for pulverizing samples such as soil, concrete, carbon fibers, chemical products, ores, gypsum, glass, semi-precious stones, wood, lime, catalysts, ceramic, bones, alloys, coal, metal oxides, minerals, pigments, quartz, slag, tobacco, tea, clay minerals, cement clinker and many more.

Sample	Feed quantity	Grinding time	Speed	Final fineness (d_{90})	Remark
Chitin	10 g	8 h	1300 rpm	<164 μm	No temperature-induced discoloring, Emax 40 °C cooler than ball mill
Polysaccharide	10 g	2 h	1800 rpm	<8.9 μm	Temperature control, max. temperature of 80 °C was not exceeded in the Emax
Wood	3 g	10 min	1300 rpm	<64 μm	Temperature limit of 30 °C was not exceeded
Titanium dioxide	10 g	30 min	2000 rpm	<80 nm	Nano grinding <100 μm was only achieved in the Emax (5x finer than ball mill result)
Barium titanate	12 g	2 h	1800 rpm	<83 nm	Nano grinding <100 μm , 3 h time saving compared to ball mill
Graphite	5 g	8 h	2000 rpm	<1.7 μm	Extreme time saving (24x faster than ball mill) and excellent fineness (7x finer than ball mill)
Cortisone derivative	2.5 g	5 min	1000 rpm	<280 nm	Temperature limit of 45 °C was not exceeded. Almost 3 h time saving compared to ball mill
Silicon & Germanium	3.63 g Si 2.36 g Ge	20 min preliminary grinding + 4 h alloying	1200 rpm	Not relevant	Mechanical alloying: Good alloying results 4–5 h faster than with ball mill, hardly any glass formation and no caking in Emax

i **Please note:** The final fineness achieved depends on the sample material and instrument configuration/settings so that apparently similar samples may lead to different results.

Faster – Finer – Cooler



Faster

Substantial time saving

The high maximum speed of 2000 rpm and the fact that the water cooling system allows for grinding without breaks in most cases result in time savings of up to 90 % when using the Emax compared to conventional ball mills. Another reason for shorter processing times is the highly effective size reduction mechanism employed in the Emax.

Nano grinding of barium titanate

Barium titanate is a ferroelectric material which belongs to the group of electrical ceramics and is used in areas like electronics and sensor technology. In this application example the requirement was to grind the barium titanate to a size below 90 nm in the shortest possible time. Thanks to the efficient size reduction mechanism and high energy input of the Emax, the desired grind size was achieved after only 2 hours whereas the Planetary Ball Mill needed 3 hours more.

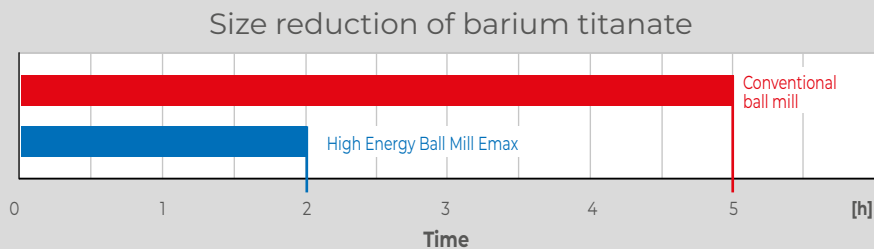

Time advantage in pharmaceutical research

A small particle size has a positive effect on the bioavailability of orally taken active ingredients. The Emax pulverizes pharmaceutical samples and ingredients to submicron and nanometer particle sizes in a very short time. This not only means substantial time savings in pharmaceutical research but also opens up new possibilities for size reduction of thermally unstable ingredients which is shown in this application example:

- A cortisone derivative was pulverized in the Emax for 5 min to below 300 nm without exceeding the critical temperature limit of 45°C
- The Planetary Ball mill required a net grinding time of 30 min with an additional 2.5 hours for cooling breaks
- Time saving of almost 3 hours in the Emax thanks to the more efficient functional principle and uninterrupted grinding

Grinding of cortisone derivative

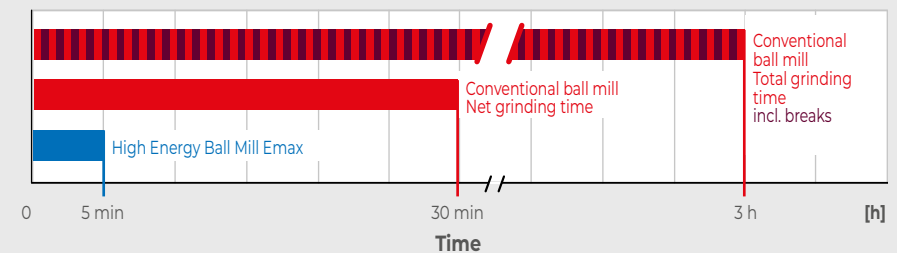

Finer

Grinding down to the nanometer range

The high energy input and the very efficient size reduction mechanism of the Emax also make it suitable for pulverizing difficult samples down to the nanometer range. Moreover, the thorough mixing of the sample leads to very narrow particle size distributions.

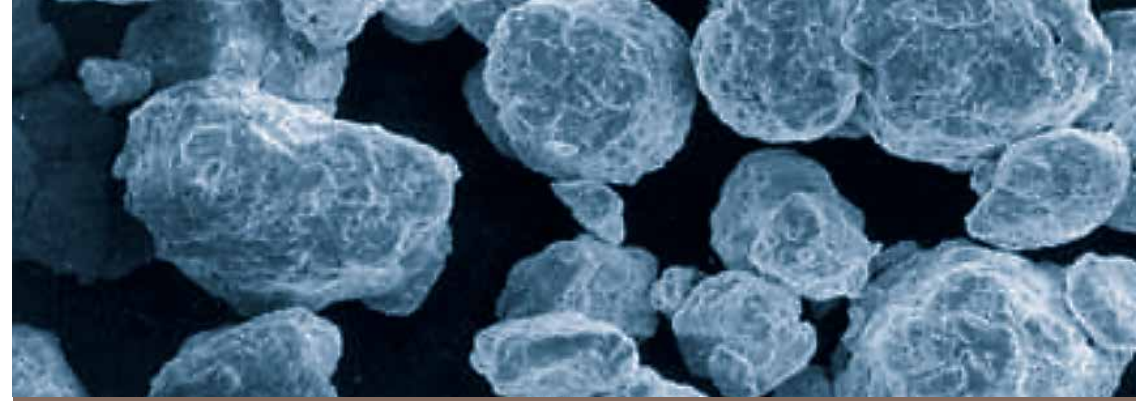

Narrow particle size distributions

Titanium dioxide is a pigment which is used, for example, in sunscreen to protect the skin from UV radiation. A particle size distribution in the nanometer range makes the protection particularly effective.

- The Emax pulverizes TiO_2 to a fineness of <90 nm within only 30 min.
- The result is 5 times finer than that of the conventional ball mill, with a considerably narrower particle size distribution.

Difficult to grind samples

Pulverization of graphite

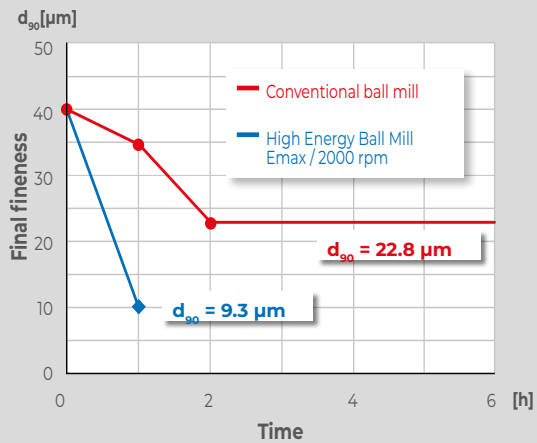

Graphite is a lubricant and therefore requires a particularly high energy input to be pulverized. After 1 hour of grinding in the Emax, already 90% of the sample were smaller than 10 microns. The best result of the conventional ball mill was a grind size >20 μm .

Pulverization of titanium dioxide

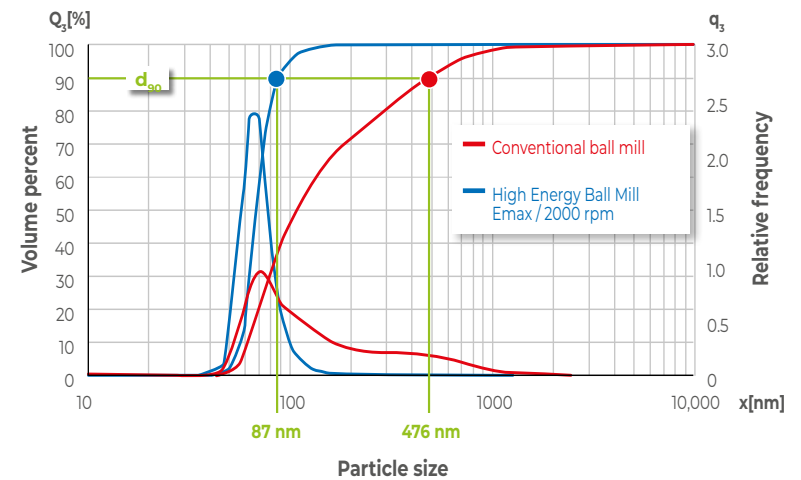

Cooler

No grinding breaks necessary

The integrated water cooling system helps to substantially reduce temperature and pressure inside the grinding jar, thus allowing for longer processing times at maximum speed without cooling breaks. It is possible to enhance the cooling effect by connecting an external heat exchanger. It is recommended to work in the temperature control mode when grinding heat-sensitive samples. It permits definition of a maximum and a minimum temperature which limit the range in which the grinding process takes place. Hence there is no need for the user to ascertain the length and frequency of cooling breaks by empirical trials.



No degradation of sample

A sample of chitin should be pulverized to a final fineness of 200 μm , and should not get warmer than 60°C to prevent degradation or discoloring. Thanks to the temperature control mode, the limit of 60°C was not exceeded in the Emax and the sample maintained its original color.

Grinding in a defined temperature range

Due to the temperature control mode the Emax is also suitable for grinding heat-sensitive samples like polysaccharide. In the following example, a final fineness below 10 microns and a maximum temperature of 80°C were required.

- The temperature range was set between 60°C and 80°C
- Break times were automatically adjusted, the 80°C limit was not exceeded
- After a process time of only 3 h the desired fineness of <math><10 \mu\text{m}</math> was achieved, unnecessary break times were avoided

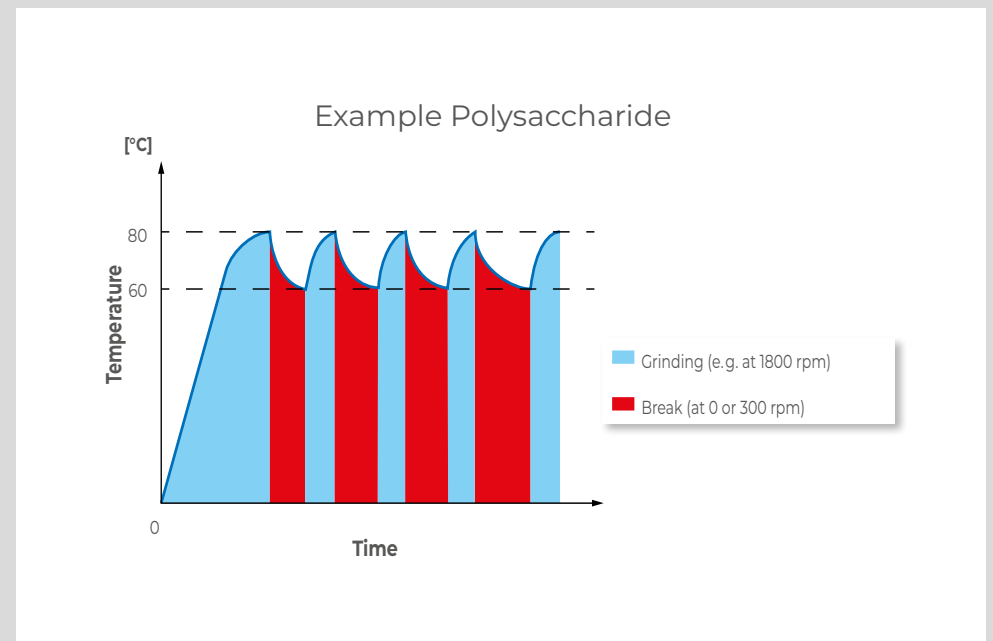

Mechanical Alloying

Excellent transformation rate and substantial time saving

For materials which cannot be alloyed by fusion, mechanical alloying is carried out in ball mills which provide high energy input through impact and friction. Trials have shown that the alloying process takes considerably less time than in, for example, a planetary ball mill. Further advantages include a better transformation rate as well as less amorphous particles and less caking.

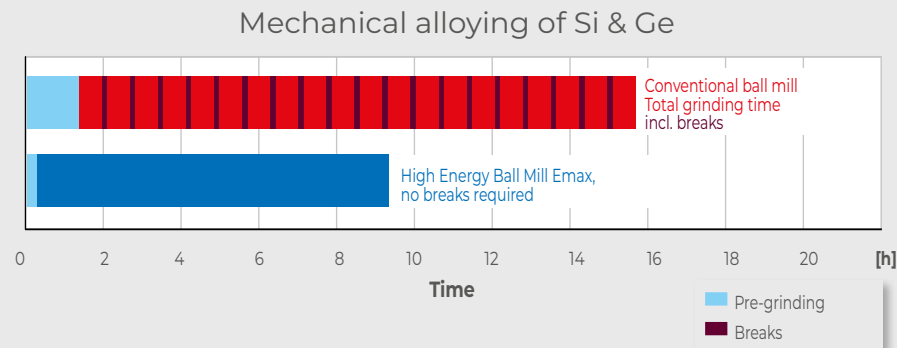

Compared to a conventional ball mill, the processing time for mechanical alloying can be substantially reduced when using the Emax. The time savings may add up to 50%.

Production of an Si-Ge alloy

To produce a silicon-germanium alloy in the Emax, first 3.63 g Si and 2.36 g Ge were pulverized in a 50 ml tungsten carbide grinding jar with ten 10 mm grinding balls of the same material. The initial particle size of the silicon ranged between 0.1 and 2.5 μm , that of germanium was approximately 4 μm . After 20 minutes of grinding at 1000 rpm the initial substances had become a loose powder. The actual alloying process was started with a powder/ball ratio of 1/10 at a speed of 1200 rpm. After 5 hours of mechanical alloying, interrupted by a 1-minute break after each hour for a direction reversal to avoid caking, the powder diffractogram already reflected the integration of germanium into silicon. After 8 to 9 hours a slight increase of this effect could be observed.

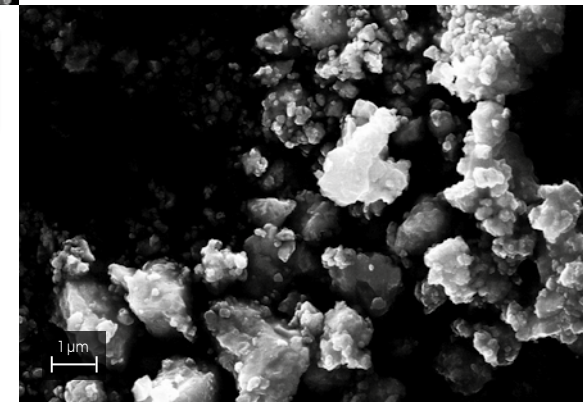
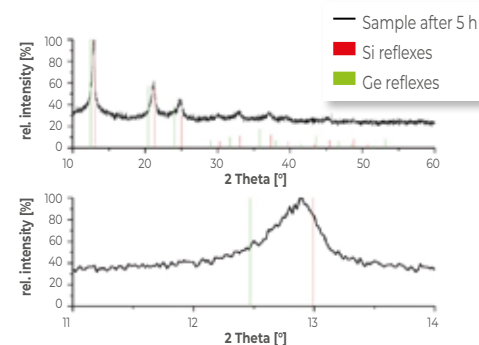
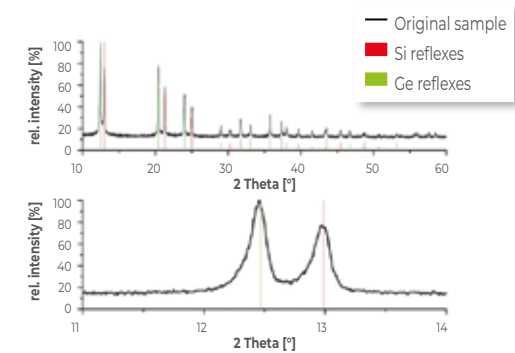
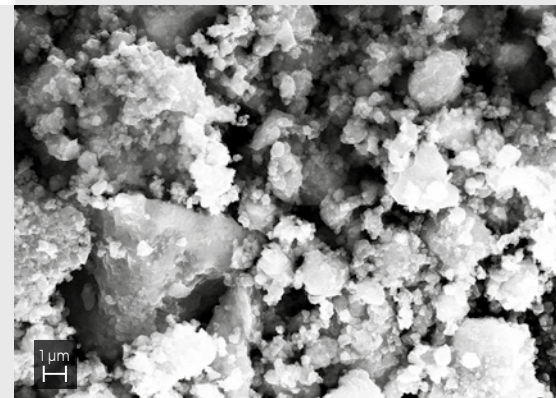



1. Grinding jars in 3 different materials
2. Aeration cover
3. Zirconium oxide grinding balls

Accessories

for safe and effective grinding processes

A wide selection of accessories makes the High Energy Ball Mill a versatile instrument. Available grinding jar sizes are 50 ml and 125 ml, materials include stainless steel, tungsten carbide and zirconium oxide, ensuring contamination-free sample preparation. The safety closure integrated in the grinding jar lid guarantees safe and convenient operation.

RETSCH offers a special aeration cover for the grinding jars designed for applications where a special atmosphere is to be maintained in the jar.

The grinding balls are available in stainless steel, tungsten carbide and zirconium oxide. Sizes range from 0.1 mm to 15 mm, depending on the material.

By selecting the adequate ball numbers and sizes, a wealth of applications can be covered.

Measuring System GrindControl

By continuously measuring pressure and temperature the processes and reactions which take place inside the grinding jar during grinding can be monitored and recorded.

Emax at a glance

Features

High Energy Ball Mill Emax

Application	nano grinding, size reduction, homogenizing, mechanical alloying, colloidal milling, high energy comminution
Fields of application	agriculture, biology, chemistry, construction materials, engineering / electronics, environment / recycling, geology / metallurgy, glass / ceramics, medicine / pharmaceuticals
Feed material	medium-hard, hard, brittle, fibrous – dry or wet
Size reduction principle	impact, friction
Material feed size*	<5 mm
Final fineness*	<80 nm
Batch size / feed quantity*	max. 2 x 45 ml
Speed	300 – 2000 rpm
Cooling	controlled integrated water cooling / option: external chiller or tap
Temperature control	yes (min and max temperature may be defined)
No. of grinding stations	2
Type of grinding jars	with integrated safety closure devices
Material of grinding tools	stainless steel, tungsten carbide, zirconium oxide
Grinding jar sizes	50 ml / 125 ml
Setting of grinding time, interval time, pause time	00:01:00 to 99:59:59
Interval operation	yes, with optional direction reversal
Storable SOPs (Standard Operating Procedures)	10
Interfaces	USB / LAN (RJ45)
Drive	3-phase asynchronous motor with frequency converter
Drive power	2600 W
Power consumption	~ 3100 W (VA)
Protection code	IP 30
W x H x D, closed	625 x 525 x 645 mm
Net weight	~ 120 kg
Standards	CE

* depending on feed material and instrument configuration/settings

Order data

High Energy Ball Mill Emax

Emax, 200–240 V, 50/60 Hz, high energy ball mill with 2 grinding stations	Item No. 20.510.0001
---	-------------------------

Grinding jars

Grinding jars	50 ml	125 ml
Stainless steel	01.462.0305	01.462.0313
Tungsten carbide	01.462.0317	–
Zirconium oxide	01.462.0312	01.462.0307

Accessories for grinding under inert atmosphere

Aeration lids for grinding jars	50 ml	125 ml
Stainless steel	01.107.0568	01.107.0567
Zirkonoxid	01.107.0569	01.107.0564

Additional items

	Item No.
O-ring for grinding jars 50 ml, 1 piece	05.114.0057
O-ring for grinding jars 125 ml, 1 piece	05.114.0122

Grinding balls

Grinding balls	0.1 mm Ø	0.5 mm Ø	1 mm Ø	2 mm Ø	3 mm Ø	4 mm Ø
Stainless steel ²⁾	–	–	–	–	22.455.0002	22.455.0001
Stainless steel ³⁾	–	–	–	22.455.0010	22.455.0011	–
Tungsten carbide ²⁾	–	–	–	–	22.455.0006	22.455.0005
Zirconium oxide ³⁾	32.368.0005	32.368.0003	32.368.0004	05.368.0089	05.368.009	–

Grinding balls	5 mm Ø	7 mm Ø	10 mm Ø	12 mm Ø	15 mm Ø
Stainless steel ¹⁾	05.368.0034	05.368.0035	05.368.0063	05.368.0037	05.368.0109
Stainless steel ²⁾	22.455.0003	–	–	–	–
Tungsten carbide ¹⁾	05.368.0038	05.368.0039	05.368.0071	05.368.0041	–
Tungsten carbide ²⁾	22.455.0004	–	–	–	–
Zirconium oxide ¹⁾	–	–	05.368.0094	05.368.0096	05.368.0113
Zirconium oxide ²⁾	22.455.0009	–	05.368.0094	05.368.0096	05.368.0113

¹⁾ 1 grinding ball ²⁾ Package with approx. 200 grinding balls ³⁾ Package with approx. 500 g grinding balls



MILLING SIEVING ASSISTING

Retsch GmbH

Retsch-Allee 1-5
42781 Haan
Germany

Phone: +49 2104 2333-100

Fax: +49 2104 2333-199



info@retschi.com www.retschi.com



VERDER scientific

VERDER SCIENTIFIC

ENABLING PROGRESS.

Under the roof of VERDER SCIENTIFIC we support thousands of customers worldwide in realizing the ambition we share.

As their technology partner behind the scenes, we deliver the solutions they need to make progress and to improve the everyday lives of countless people. Together, we make the world a healthier, safer and more sustainable place.

